



UIPM

Technical Newsletter - 2025/2

Technical Newsletter

Dear Member Federations, Coaches, Athletes and Technical Officials

This edition of the Technical Newsletter provides clarifications on the Modern Pentathlon Competition Rules, with Section A outlining the actions required of LOCs when conducting Obstacle competitions under wet conditions, as referenced in Article 3.4.1, and Section B detailing health and safety protocols linked to Article 3.12.4.

A

COMPETITION IN WET CONDITIONS

Suspension Obstacles

The final surface layer of all hanging obstacles, except for monkey bars and ascension bars, shall be coated with a material incorporating an anti-slip additive to enhance grip and durability in wet conditions.

There are fast-drying spray solutions available on the market (20-30 minutes) that adhere to various materials, including metal, plastic, wood, and composites. These coatings provide long-lasting traction, creating a durable, textured, and hand-friendly surface.

Start/Take off/landing platforms

The surface of the platforms shall be covered with non-slip adhesive tape strips to ensure adequate traction for athletes. This type of tape is commonly used for stairways, ramps, and other high-traffic areas to enhance safety and prevent slipping. The placement of the tape strips should follow the measurements detailed in the image below.

- The tape shall be of high quality, consisting of abrasive particles bonded by a durable polymer to ensure superior traction and durability. The texture shall feature a medium to coarse grit, offering a secure grip while ensuring comfort for athletes in case of fall.
- The reverse side of the tape shall be coated with a pressure-sensitive adhesive made from weather-resistant PVC or polyester film.
- The tape shall be 5 cm wide, with an industrial-grade adhesive to maintain a strong bond, even in humid or rainy conditions, preventing peeling.
- To ensure maximum efficiency when applying the tape to the surfaces, it is highly recommended to use a Rubber Hand Roller, which provides a firm bond when sticking the tape to the surface.

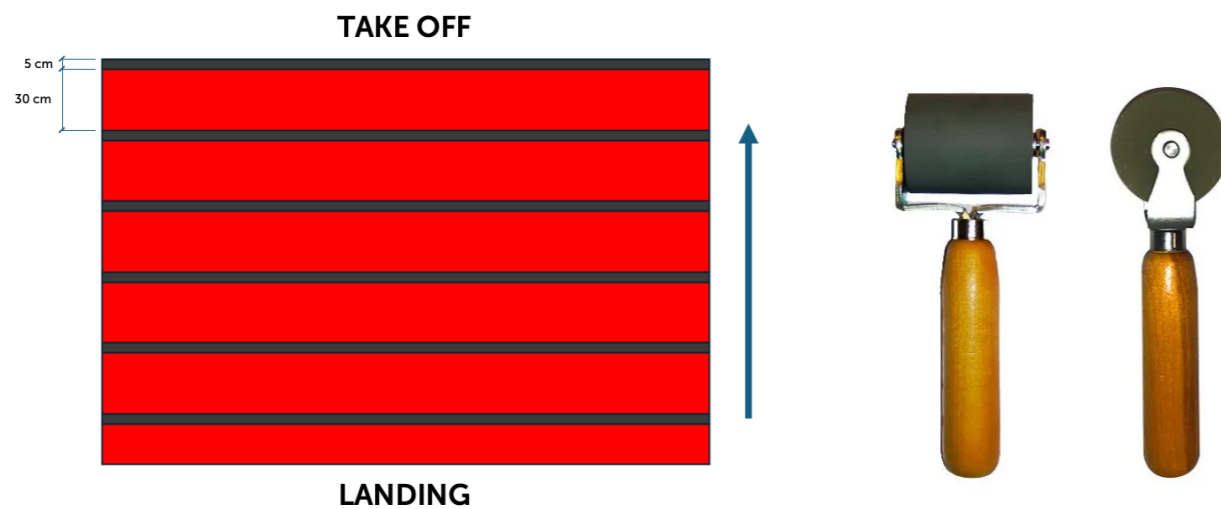

Image 1. Detail of platform

Image 2. Rubber Hand Roller

Finish Wall

The Local Organizing Committee shall ensure that the surface of the finish wall is covered with a rubberized non-slip coating made from weather-resistant, polymer-based materials with a medium-grit texture for adequate traction. The coating must have high adhesion properties, a thickness of 1-2 mm, and be safe, non-abrasive, easy to clean, and suitable for varying environmental conditions, offering durability and flexibility.

Additionally, three non-slip zones, each 45 cm wide, must be marked on the wall using tape identical to that used on the platforms. The center of these zones shall be positioned at 1 m, 2 m, and 3 m along the wall's horizontal projection (parallel to the ground). Each zone will contain three 5 cm-wide strips, evenly spaced 15 cm apart, ensuring consistent grip across the designated areas.

A metal bar, identical to the one used as a monkey bar, may be installed 50 cm below the top edge of the finish wall to assist athletes in climbing. The distance between the back part of the bar and the finish wall shall be 20 cm, and the bar's position must be parallel to the ground. The bar must be securely anchored to the ramp structure to prevent movement, and its deflection should be minimized by using a stopper in the middle, which will rest against the wall for additional support.

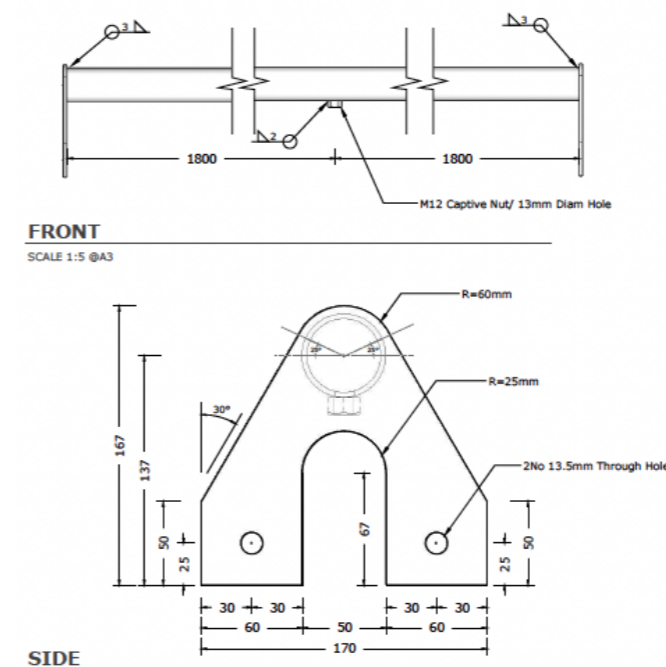

Image 3. Bar Detail

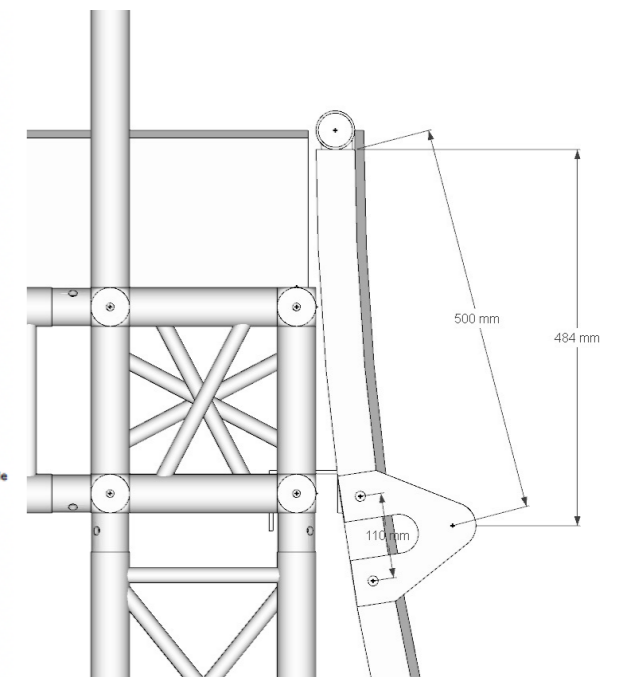

Image 4. Bar Connection Detail

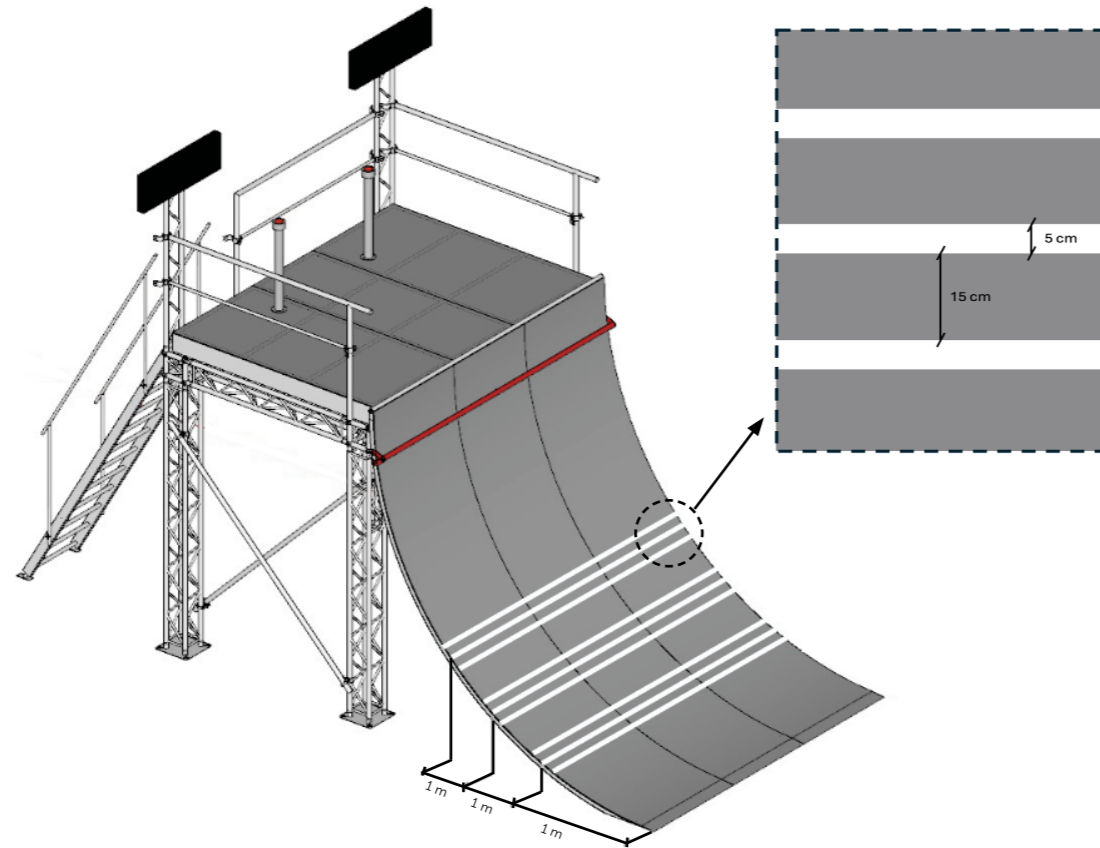

Image 5. Perspective of the Finish Wall

B

HEALTH AND SAFETY PROTOCOLS

In addition to the procedures outlined in Article 3.12.4 – Medical Provision – of the competition rules and regulations, athletes who present with visible traces of blood on their hands in the obstacle call room shall be required to cover such traces with medical tape prior to the commencement of their heat.

During the Call Room Inspection, this situation will be evaluated as needed by one of the following authorities, according to the priority order: 1) UIPM Medical Delegate, 2) LOC Medical Doctor, and 3) UIPM Technical Delegate, who will determine the medical tape covering to ensure full compliance with health and safety protocols. This action is mandatory to preserve both the safety of the athlete and the integrity of the competition environment, ensuring fairness for all participants.

UIPM HEADQUARTERS

Stade Louis II – Entrée C
19 avenue des Castelans
Tel. +377 9777 8555 | Fax +377 9777 8550
E-mail: uipm@pentathlon.org

WEB

www.uipmworld.org

SOCIAL MEDIA

 /WorldPentathlon
  /WorldPentathlon
  /uipmchannel
  /theuipm